



F8N-90

Tapping Unit

Specification

Tapping Capacity	M45(mild steel)
Stroke	90mm
Thread Pitch	0.8mm~3.0mm
Weight	65kg
Gauge Lubrication	Grease
Transmission	a. RS40-2 row-30T b. HTD-8YU-48T

Consumption Parts

Spindle Bearing	32010x1, 30209x1
Pulley Bearing	6212Zx1, 6212ZZx1
O-Ring for Spindle	TC-60.80.12x1, TC70-90.12x1
O-Ring for Rear Cover	TC100-125.13x1

- The unit is mounted with high precision, ground master gauge for precision and fine tapping works.
- Thread pitch should be given when ordering.
- Master gauge is mounted externally to the end of unit for easy and quick change.
- This unit can be mounted horizontally or vertically, oil cup should be adjusted accordingly.
- To increase life of master gauge, install tension spring for vertical application is recommended.
- For mounting multiple spindle head, please choose model : F8N-90-MT4B.

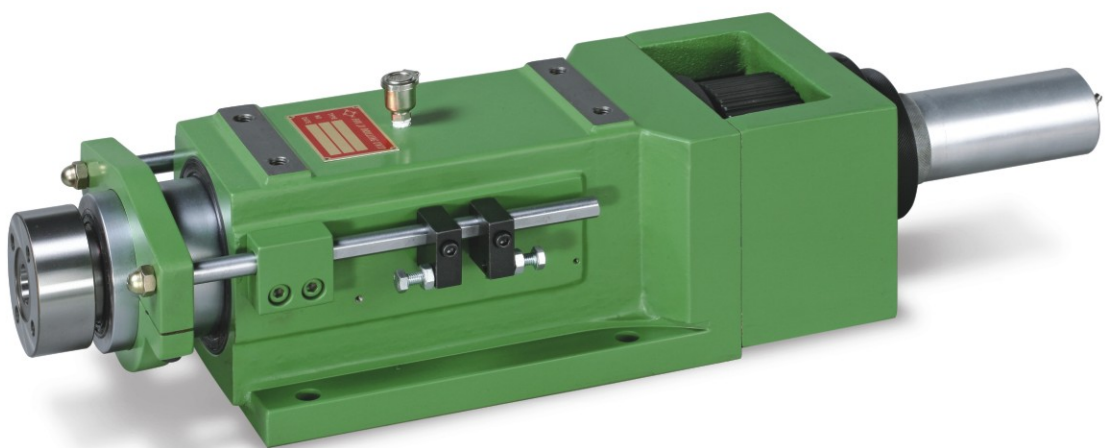



F8N-90

Tapping Unit

■ Dimensions

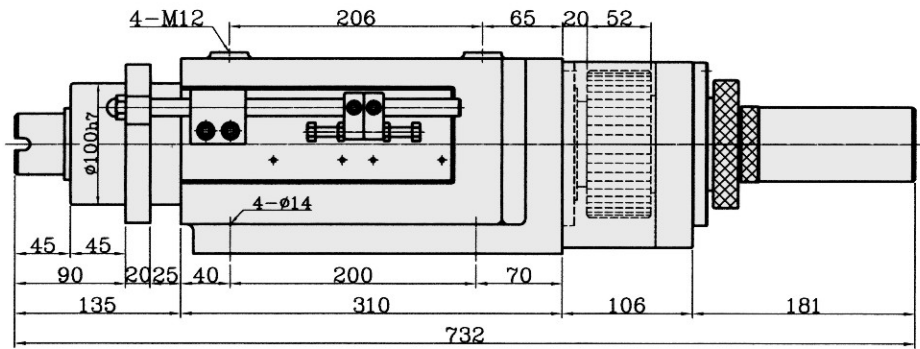
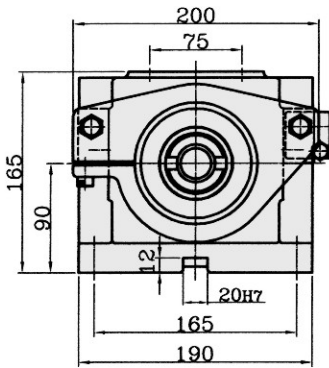

F8N-90-AS36

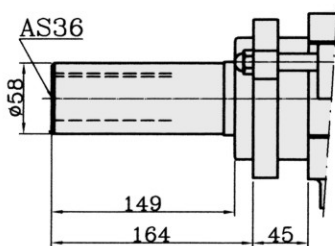

F8N-90-FB30

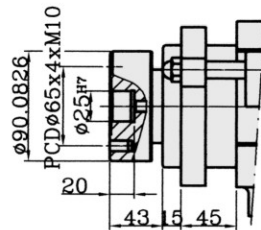

F8N-90-MT4B Multi

